

New insights on the modular planning of the Taj Mahal

R. Balasubramaniam

Department of Materials and Metallurgical Engineering, Indian Institute of Technology, Kanpur 208 016, India

Dimensional analysis has revealed that the modular planning of the Taj Mahal complex was executed using the traditional measurement units mentioned in the *Arthashastra*, and, in particular, the *vitasti* measuring 12 *angulams* of 1.763 cm. The riverfront terrace and garden sections of the complex were planned using square grids of 90 *vitasti* to the side, while the forecourt and caravanserai section using square grids of 60 *vitasti* to the side. The logical numbers that result for the dimensions have been analysed to show the ease of division of these numbers into symmetric elements to understand quadratic division of space of the garden area and the triadic division of space of the mausoleum, including decimal divisions. A novel approach to understand the metrology of historical architectural structures of the Indian subcontinent is revealed.

Keywords: *Arthashastra*, architecture, measurement, metrology, Taj Mahal.

THE Taj Mahal complex is one of the most visited and well-known archaeological structures of India. This is also one of the wonders of the modern world¹. The overall plan of the Taj Mahal complex (Figure 1) reveals that it was planned based on ordering of grids, with the main architectural features of the complex placed on bilateral mirror symmetry along the north-south axis. The four major sections of the complex, as they are referred to in Figure 1, are (*T*) the riverfront terrace which contains the Taj Mahal mausoleum (*M*), (*C*) the *charbag* (literally ‘four gardens’) in front of the riverfront terrace, (*J*) the *jilaukhana* (literally ‘in front of the house’) which contains the gate (*G*), and finally, the caravanserai (*S*).

The first detailed scholastic examination of the modular planning of the complex was undertaken only in 1989, when Begley and Desai² analysed the measurements of different parts of the complex listed by Lahori³. Lahori was the official historian of Shah Jahan (AD 1628–56), who commissioned the construction of the Taj complex. Lahori stated the measures in terms of the *gaz* and *zira*, which were Mughal linear measures^{4,5}. One notices that the entire description of the dimensions of the complex by Lahori³ is in terms of mainly illogical *gaz* figures. The appearance of illogical numbers in the design of the Taj

complex and the Taj Mahal has been ignored so far and simply considered as being part of geometric understanding^{2,6}. Begley and Desai² proposed a simple fixed grid of 400 *gaz* and its sub-divisions to describe the complex, but their analysis has been shown to be imprecise and incorrect⁶.

Recently, Barraud⁷ recorded the most detailed dimensions of the complex and proposed a generated grid system to explain the modular layout of the complex⁶. Barraud utilized the traditional Mughal linear measure, *gaz*, assuming a conversion of 80.5 cm to a *gaz*. He concluded that the complex was planned as a tripartite rectangle composed of three 374-*gaz* squares⁶. Barraud proposed that the planning of the riverfront terrace and the *charbag* sections can be understood in terms of square grids of 23 *gaz* to the side, while that of the *jilaukhana* and caravanserai sections in terms of square grids of 17 *gaz* to the side. Further, he noted that the transition from the 23-*gaz* grid pattern to the 17-*gaz* grid pattern occurred at the main gate (marked as *G* in Figure 1). The apparent illogicality in the numbers 23 and 17 of the sides of the grid patterns proposed by him is immediately striking, when the grid sides are expressed in terms of *gaz*. Barraud⁶ has ignored the appearance of illogical numbers and the discrepancies in the measurement (which are primary evidence) as being due to errors in the contemporary descriptions, rounding-off errors, inaccuracies of reporting from third persons and errors in workmanship. These arguments are not convincing since the planning of the complex is precise and the quality of workmanship is par excellence.

The modular planning of the complex can be viewed afresh from a totally different angle, by considering the use of a different system of measurement. Recent studies^{8–10} have revealed that the measurement units described in Kautilya’s *Arthashastra*^{11,12}, dated to around 300 BC, can be used to understand the engineering plans of most engineered structures of the Indian subcontinent through the ages, till the adoption of British units in early twentieth century. In particular, these studies confirm the use of a constant basic measurement unit (the *angulam*) of 1.763 cm. Interestingly, this unit was derived, without any a priori assumptions, from plans of Harappan civilization settlement sites^{13,14}. A similar unit also appears in the Lothal ivory¹⁵ and Kalibangan terracotta¹⁶ scales of the Harappan civilization. The important measures men-

e-mail: bala@iitk.ac.in

RESEARCH ACCOUNT

tioned in the *Arthasastra* have been summarized in Table 1 in terms of the traditional *angulam* and modern centimetre. These measurement units have been explained in greater detail elsewhere¹⁰.

The first detailed measurements of the Taj Mahal complex were made by Hodgson¹⁷, the then Surveyor General of India, in 1825. The latest measured dimensions of Barraud⁷ will be utilized in this article.

Riverfront terrace and *charbag*

The modular design of the riverfront terrace and *charbag* area can be understood in terms of square grids of each side corresponding to 10 *dhanus* (henceforth 10D). This

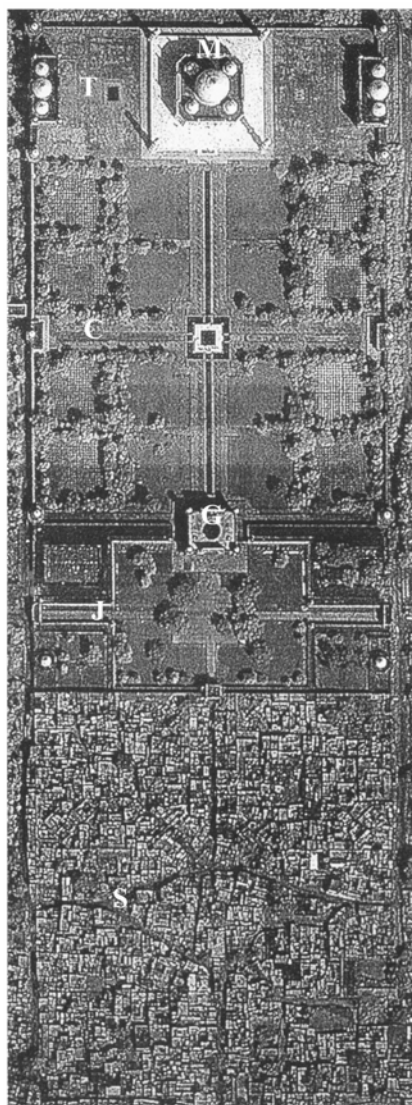

Figure 1. The four sections of the Taj Mahal complex have been marked in this satellite image of the complex. These are (T) the riverfront terrace (northernmost), (C) the *charbag*, (J) the *jilaukhana* and (S) the caravanserai. M is the Taj Mahal mausoleum and G the grand gate.

modular plan has been shown in Figure 2. The important lengths in the riverfront and *charbag* sections have also been indicated in Figure 2 in terms of *dhanus* (D).

The intricate construction of the Taj Mahal mausoleum must have required measures smaller than *dhanus*. It is most logical to consider the traditional hand span measure

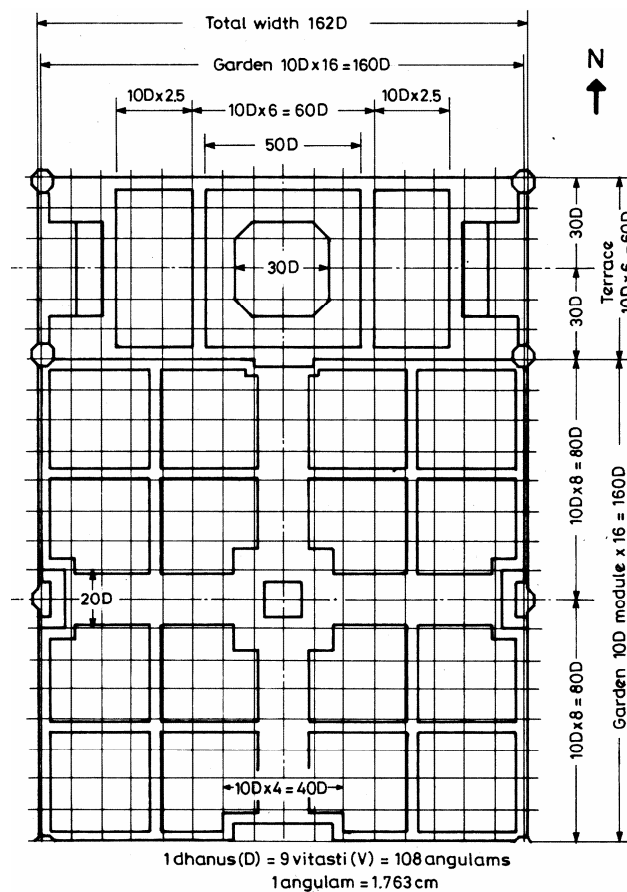

Figure 2. Proposed novel modular plan and predicted dimensions of the riverfront terrace and *charbag* sections of the Taj Mahal complex, based on the modular grid of 10D. The *dhanus* (D) equals 108 *angulams* and each *angulam* measures 1.763 cm.

Table 1. Units of measure mentioned in the *Arthasastra* in terms of number of *angulams* and centimeters, using the conversion 1 *angulam* = 1.763 cm. This table is fundamental to the understanding of metrology of the Indian subcontinent through the ages. The different kinds of *hastas* are explained in Balasubramaniam¹⁰

Measure	No. of <i>angulams</i>	Centimetres
<i>Angulam</i>	1	1.763
<i>Vitasti</i>	12	21.256
<i>Pada</i>	14	24.682
<i>Aratni</i>	24	42.312
<i>P-hasta</i>	24	42.312
<i>C-hasta</i>	28	49.364
<i>F-hasta</i>	54	95.202
<i>Kishku</i>	42	74.046
<i>Kamsa</i>	32	56.416
<i>Danda</i>	96	169.248
<i>Dhanus</i>	108	190.404

Table 2. Comparison of the proposed dimensions with the most recent actual measurements⁷ of important sections of the Taj Mahal complex. The *vitasti* (V) equals 12 *angulams* and each *angulam* measures 1.763 cm

Location	Proposed measure		Actual measure (cm)	Percentage error
	<i>Vitasti</i> (V)	Centimetre		
E-W length of terrace	1440	30464.64	30084	+1.25
N-S length of terrace	540	11424.24	11189	+2.06
E-W and N-S lengths of marble platform	450	9520.20	9569	-0.51
E-W and N-S lengths of mausoleum plinth	270	5712.12	5690	+0.39
E-W and N-S length of <i>charbag</i>	1440	30464.64	29631	+2.74
E-W length of platform on gate facing <i>jilaukhana</i>	300	6346.80	6436	-1.41
N-S length of platform on gate facing <i>jilaukhana</i>	120	2538.72	2620	-3.20
Length of door in gate on N/S face	60	1269.36	1290	-1.63
Length of door in gate on E/W face	45	952.02	975	-2.41
E-W length of central hall in gate	60	1269.36	1290	-1.63
E-W and N-S length of central square of corner room in gate	24	507.74	525	-3.40
E-W length of <i>jilaukhana</i>	1440	30464.64	30084	-1.25
E-W length of court in <i>jilaukhana</i>	780	16501.68	16523	-0.13
N-S length of court in <i>jilaukhana</i>	600	12693.60	12351	+2.70
E-W length of bazaar street in <i>jilaukhana</i>	300	6346.8	6250	+1.53
N-S length of bazaar street in <i>jilaukhana</i>	75	1586.70	1618	-1.97
E-W length of south gate in <i>jilaukhana</i>	60	1269.36	1220	+3.89
E-W length of inner enclosure of attendants' quarters in <i>jilaukhana</i>	240	5077.44	4965	+2.21
N-S length of inner enclosure of attendants' quarters in <i>jilaukhana</i>	165	3490.74	3522	-0.90
E-W length of outer enclosure of attendants' quarters in <i>jilaukhana</i>	300	6346.8	6185	+2.55
N-S length of outer enclosure of attendants' quarters in <i>jilaukhana</i>	240	5077.4	5366	-5.68
E-W length of caravanserai	1440	30464.64	30084	-1.25
N-S length of caravanserai	1560	33003.36	33490	-1.47
E-W length of central street of caravanserai	120	2538.72	2530	+0.34
E-W and N-S length of typical courtyard of caravanserai	660	13962.96	13777	+1.33

the *vitasti*. The *Arthasastra* specifically mentions that 12 *angulams* equal one *vitasti* (V). There is no confusion regarding its exact value in terms of *angulam*, unlike some other units like *hasta* (see Table 1 and Balasubramaniam¹⁰ for definitions) mentioned in the *Arthasastra*. Therefore, 10 *dhanus* equals 90 *vitasti*. This is the grid size used in the modular planning of the riverfront terrace and *charbag* sections.

In order to bring out the accuracy of the dimensions mentioned in Figure 2, the errors between the proposed and actual measures are listed in Table 2. The proposed measures have been expressed in units of *vitasti* and centimetres. The measured values are the most recent⁷. The error is defined as the deviation of the proposed measure from the actual measure expressed in percentage of the proposed measure. The good match of the predicted measures with the actual measured values confirms the novel approach presented in this article, namely the original modular planning of the riverfront terrace and *charbag* sections used a grid of pattern of 10D or 90V to the side.

It may also be worth noting here that the classical unit of *rajju* is defined as 10 *dhanus* in the *Arthasastra*^{11,12}. Therefore, the perfect expression of several measures in the Taj Mahal complex in terms of *rajju*s could hardly all be coincidences. Although the *rajju* will not be used fur-

ther in this article, its relationship with the *dhanus* must be borne in mind.

Of great advantage in using measures expressed in the *Arthasastra* units is the fact that the Taj Mahal complex can be divided into sections whose measures are in logical numbers. A major dimension is the breadth of the entire complex. This works out to be 160D or 1440V, if one does not include the wall enclosure at the sides (Figure 2). Further, the extent of the riverfront terrace (i.e. the dimensions in the N-S axis) is 60D.

The quadrilateral four part symmetry of the *charbag* is evident in Figure 1. The length and breadth of the garden is 160D. The four-fold symmetry that is inherent in its design is readily evident when the dimension is expressed as 160D or $(4^2 \times 10)D$ or $(2^4 \times 10)D$. For example, the *charbag* grid of 160D by 160D can be further divided into grids of increasing complexity like four (which is 2^2) grids of 80D by 80D, eight (which is 2^3) grids of 40D by 40D, sixteen (which is 2^4) grids of 20D by 20D, two hundred and fifty-six (which is 2^5) grids of 10D by 10D, and one thousand and twenty-four (which is 2^6) grids of 5D by 5D.

The appearance of the multiple 10 in the measure of the grid side (considering either 10D or 90V) is also significant because it allows division of space using the decimal system.

Transition zone

There is no apparent symmetry in the grid pattern proposed by Barraud⁷ for the great entrance gate set in the centre of the southern wall of *charbag* (see Figure 3). Barraud’s modular plan does not highlight the inherent symmetry of the structure.

A detailed analysis of the plan of the gate revealed that the gate must be considered as part of the *jilaukhana* section and the modular unit that can coherently express its design as well as the dimensions of its architectural features is a grid pattern of 60V to the side. The modular plan of the grand gate using a grid pattern of 60V is shown in Figure 4. The overall symmetry of the gate can be easily appreciated using this plan. Further, the fine division of the 60V × 60V grids into smaller ones can realize the entire design of the gate. The E–W length (3 × 60V) is also equal to twice the length of the nearby garden grid (2 × 90V), highlighting the smooth transition in modular design from the *charbag* to the *jilaukhana* sections.

A good match of predicted and actual values of several architectural features of the gate must be noted in Table 2. One probable reason for the slightly higher errors noted

in some predicted measurements of the gate in Table 2 could be that the actual end-points of the measurement may not have been clear, even in the latest measurements taken by Barraud⁷. A few alterations in the plan (during restoration and conservation of the heritage complex) since the time of the construction may be another reason for the higher percentage of errors in certain cases.

The above analysis, nevertheless, confirms the novel proposal of use of grids of 60V size in the modular planning of the Taj complex, in addition to grids of 90V in size. This novel modular plan using grids of size 60V to the side will now be applied to plans of *jilaukhana* and *caravanserai* sections.

Jilaukhana and caravanserai sections

A novel scheme of dividing the *jilaukhana* space using modular units of 60V to the side is presented in Figure 5. In this figure, the 90V modular grid of the adjoining *charbag* has been indicated at the top using dotted lines. The 60V modular grid has been marked on the northwest corner. All the major architectural features in this section have been laid out based on this grid pattern (Figure 5). The inner and outer enclosures of one of the complex that

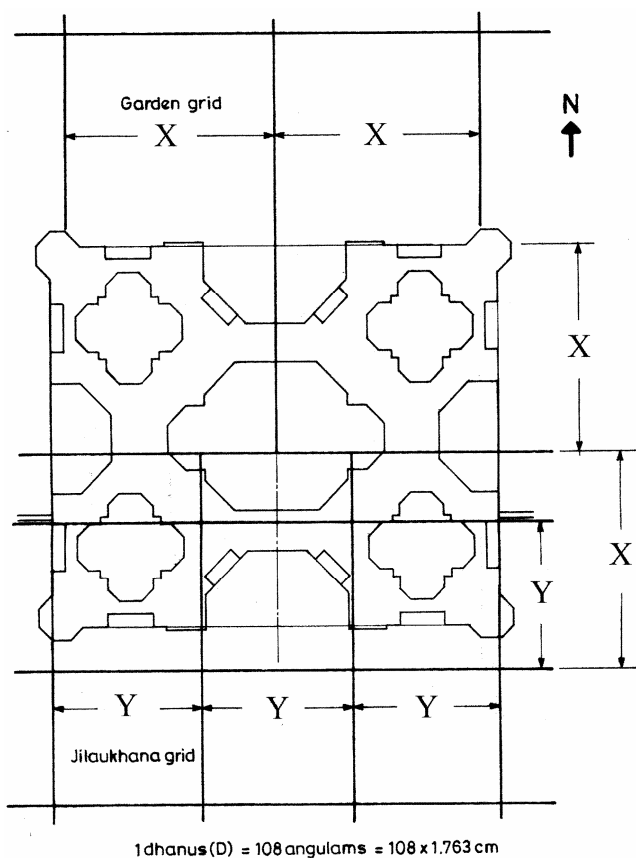

Figure 3. Modular plan of the main gate separating the *jilaukhana* from the *charbag* based on the modular grid design of Barraud⁶. The striking lack of symmetry in the modular plan must be noted. In this figure, the 23-gaz unit is referred to as X and the 17-gaz unit as Y.

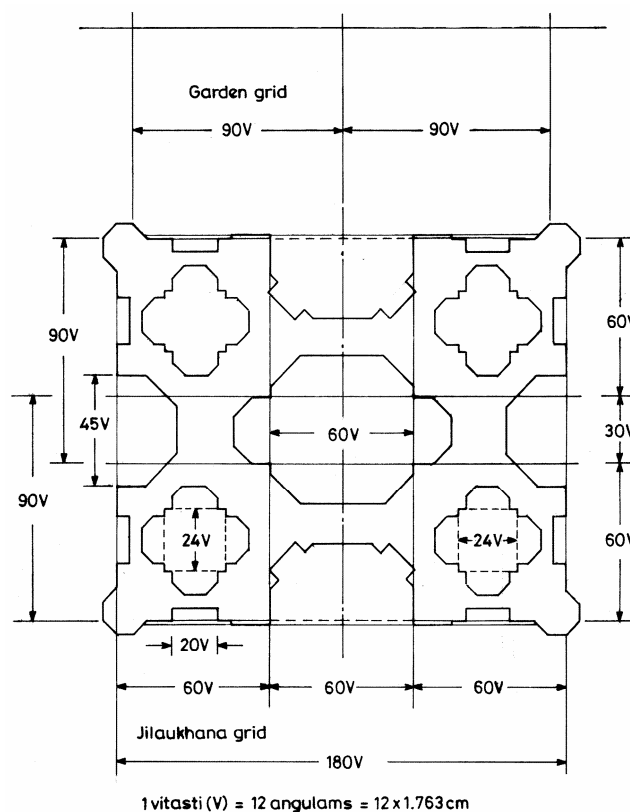

Figure 4. Proposed novel modular plan and predicted dimensions of the main gate between *jilaukhana* and *charbag* sections based on modular grid of 60V. The *vitasti* (V) equals 12 *angulams* and each *angulam* measures 1.763 cm.

housed the quarters of attendants have been marked in the northeastern side of the *jilaukhana*. The street has been indicated by dotted lines. The predicted dimensions of major architecture features are indicated in this figure in units of *vitasti* (V). The match of predicted values with measured ones⁷ is good (see Table 2).

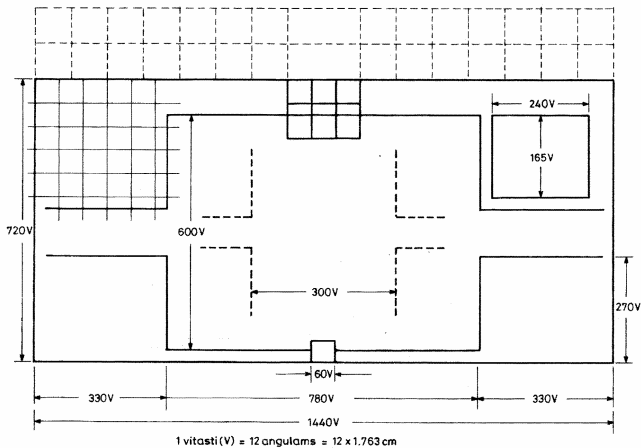

Figure 5. Proposed novel modular plan and predicted dimensions of the *jilaukhana* section, based on modular grid of 60V. The *vitasti* (V) equals 12 *angulams* and each *angulam* measures 1.763 cm. The 90V grids of the modular plan of the adjoining *charbag* section are marked at the top using dotted lines.

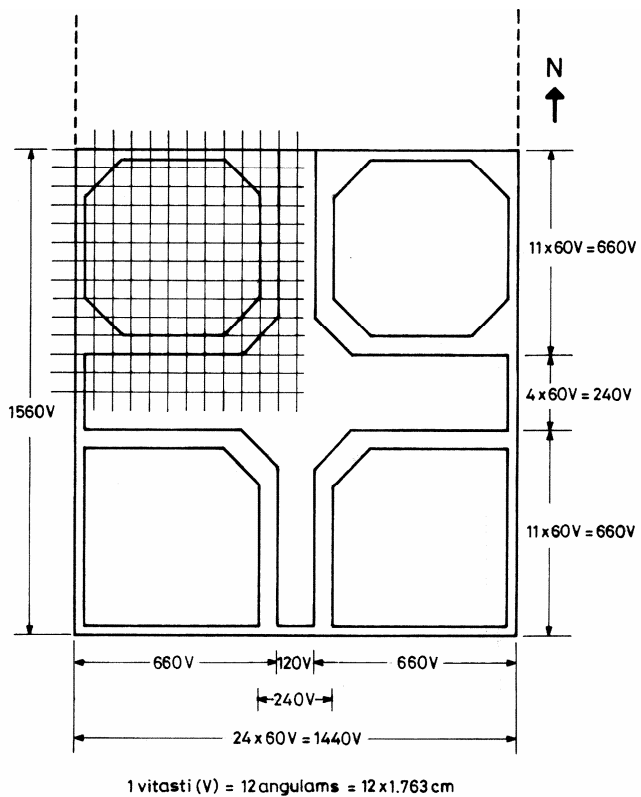

Figure 6. Proposed novel modular plan and predicted dimensions of the caravanserai section, based on a modular grid of 60V. The *vitasti* (V) equals 12 *angulams* and each *angulam* measures 1.763 cm.

The modular plan of the caravanserai section can also be understood in terms of the 60V grid pattern. This plan is shown in Figure 6, where the dimensions of important features have been marked. The 60V grid pattern has been marked at the top left quadrant. The excellent match between the proposed and actual dimensions (see Table 2) confirms that this was probably the plan on which this section was designed.

Overall design

The overall plan of the Taj Mahal complex along with dimensions of the different sections is shown in Figure 7,

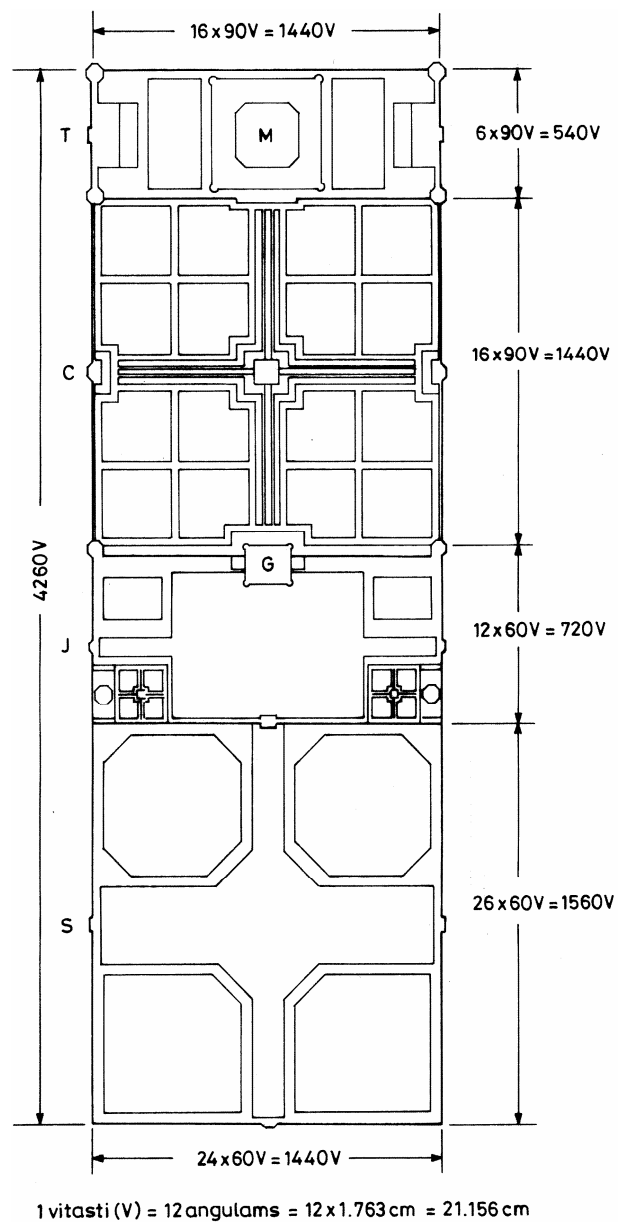

Figure 7. Proposed dimensions of the Taj Mahal complex in terms of *vitasti*. The *vitasti* (V) equals 12 *angulams* and each *angulam* measures 1.763 cm.

RESEARCH ACCOUNT

with dimensions expressed in terms of *vitasti* (V). The riverfront terrace and *charbag* sections occupy 540V and 1440V length along the N–S axis respectively. The *jilaukhana* and the caravanserai sections occupy 720V and 1560V length along the N–S axis respectively. According to this plan, the overall length of the complex is 4260V (= 90124.56 cm). The actual measured value⁷ is 89,610 cm, which is close to the prediction (off by error of +0.57%). This remarkable match confirms the novel modular planning scheme of the Taj complex, explained in this article.

It was confirmed earlier that a large grid size (90V) was used in the modular planning of the terrace and *charbag* sections, while a smaller grid size (60V) was used for the *jilaukhana* and caravanserai sections. Although the overall dimensions of the *jilaukhana* and caravanserai were larger, they were divided using a finer grid. The transition of these two grid patterns was achieved at the main gate to the *charbag* (see Figure 4). The entire *charbag* and mausoleum present a striking picture when one enters through the impressive gate. It is reasonable to propose that one of the main reasons for this visual effect is the entirely different (and larger) grid pattern on which the riverfront terrace and *charbag* sections were planned, compared to the smaller grid pattern on which the *jilaukhana* and the caravanserai sections were planned.

The mausoleum

The most spectacular engineering construction in the complex is the Taj Mahal mausoleum.

The relative dimensions of the platform and the plinth (on which the mausoleum rests), and their relation to the N–S length of the riverfront terrace are shown in Figure 8. The length and breadth of the marble platform is 450V, while the length and breadth of the plinth of the mausoleum equals 270V. The match between predicted and actual measurements is excellent (see Table 2). In this manner, the square (representing the plinth of the mausoleum) of 270V to the side was planned in the centre of another square (representing the marble platform) of 450V to the side. Incidentally, these dimensions are symmetrically related to the N–S length of the terrace, which equals 540V. The minarets are located at the four corners of the platform along the common diagonal axes. The overall symmetry of this design scheme can be appreciated in the plan shown in Figure 8.

The proposed modular plan and dimensions of different sections of the mausoleum are shown in Figure 9. The mausoleum was designed on a master square of 270V to the side. The appearance of number 270 (= 3 × 3 × 3 × 10) in the modular planning is noteworthy, because of the many ways in which space represented by a square of 270V sides can be divided. Apart from the triadic divi-

sion (division of space by thirds, which dominate the plans, elevations and architectural ornaments of the Taj Mahal), 270 lends itself to other combinations, reflected in Figure 9, which are discussed below.

Additionally, the factor 10 in 270 facilitates the decimal division of dimensions. This is important, especially considering the intricate inlay and exquisite mosaic work on the walls and floor of the Taj Mahal, which were planned and executed to a well-devised scheme. The present article will not analyse the minor dimensions of the numerous symmetric geometric patterns seen in the Taj Mahal, but it is clear that their dimensions¹ can be rationally understood in terms of the traditional *vitasti* unit of the *Arthasastra*.

The plan of the mausoleum can be divided into nine smaller squares of side 90V (see Figure 9). This kind of division of square space into nine equal squares was also followed in ancient Indian¹⁸ and Chinese¹⁹ cultures. Further subdivision of the 90V length in thirds is evident in the length of the large arched doors (60V) and the small arched doors (30V) on each (outer) face of the mausoleum (see Figure 9). The predicted value for the large door length is 1269.36 cm (=60V) and this is only

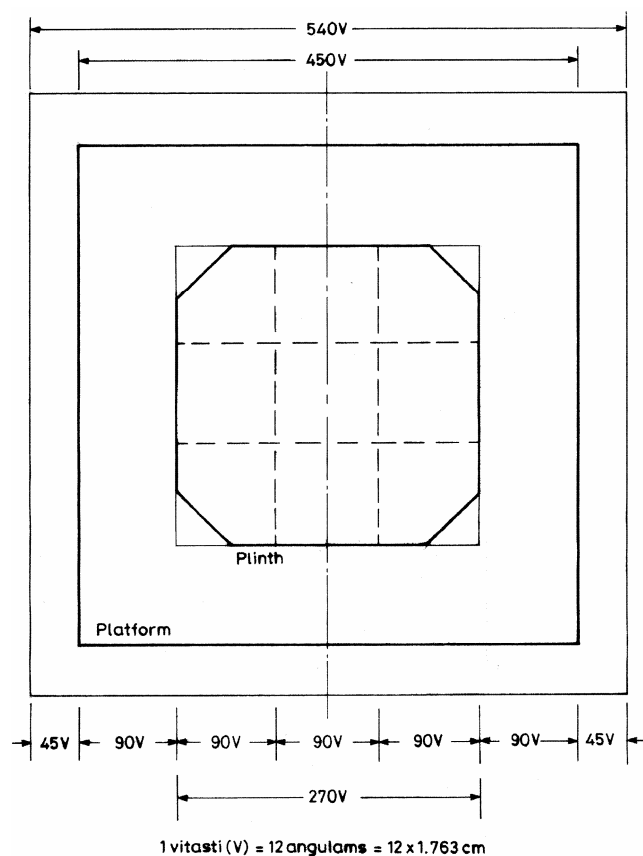

Figure 8. Proposed modular plan and predicted dimensions of riverfront terrace containing the marble platform on which the plinth of the Taj Mahal rests. The *vitasti* (V) equals 12 *angulams* and each *angulam* measures 1.763 cm.

-1.70% away from the average measured value⁷ of 1291 cm.

The lengths of several major sections and architectural elements of the Taj Mahal reveal that the side of length 270V was also divided into other different schemes, like 60V + 150V + 60V or 45V + 180V + 45V. These possibilities have been marked in Figure 9. The division of the 270V side into unequal lengths of 60V + 150V + 60V results in the grid pattern whose intersection points match precisely the centres of the octagonal chambers on the four corners. This grid pattern has been shown by a dotted line in Figure 9. Using the scheme of dividing the 270V length into lengths of 45V + 180V + 45V, one can appreciate the design of the chamfered corners of the Taj Mahal. Considering each corner square of dimensions 45V by 45V, it is first noted that the length of the corner section does not correspond to the length of the diagonal of this square (namely $(45/\sqrt{2})V = 63.63V$). The corner has been designed such that its length is 45V and the length of the corner door archway is 30V (see bottom part of right hand side of Figure 9).

Central chamber

The central square of the nine-square ($9 \times 90V \times 90V$) modular plan of the Taj Mahal contains the tomb chamber and can be analysed according to the plan proposed in Figure 10. The central octagon is enclosed in a square of $(90V/2) \times (90V/2)$. This equal-sided octagon outlines the screened area surrounding the central tomb. Since the octagon is equal-sided and fully inscribed within a square of $(90V/2)$ to the side, the length of each side of the octagon can be precisely determined by mathematical methods

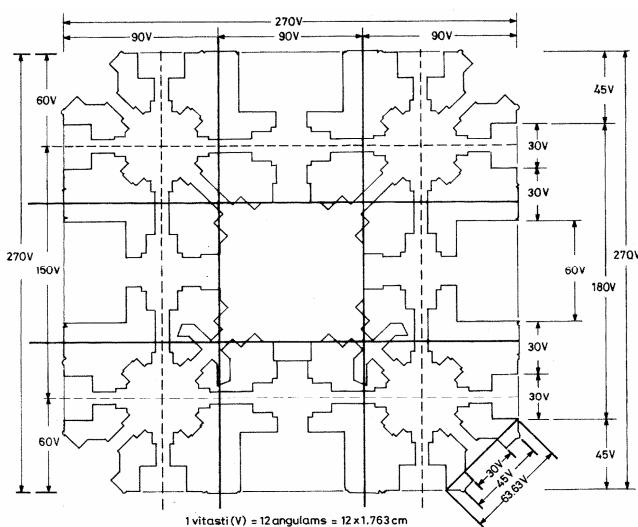

Figure 9. Proposed modular plan and predicted dimensions of the Taj Mahal mausoleum. The *vitasti* (V) equals 12 *angulams* and each *angulam* measures 1.763 cm. The symmetric dimensions of various architectural features of the structure must be noted.

The mathematical solution of this geometric problem gives the length of each side of the octagon as $(90V/2) \times \tan(90/4) = 18.6396V$. This measure has also been marked in Figure 10. The architectural feature that matches this central octagon (in Figure 10) is the large octagonal design on the mosaic floor, just outside the exquisite screen.

The average measured length³ of the side of the octagonal screen is 359 cm. The average length of each side of the octagonal design in the mosaic is 394 cm, based on the detailed plan of the mosaic flooring¹. The predicted value of the length of each side of the central octagonal design is $(18.6396 \times 21.256 \text{ cm}) = 394.340 \text{ cm}$. This excellent match of the predicted dimensions with the average length of the large central octagonal design on the mosaic floor must be considered as firm proof for the novel analysis presented in this article.

A word of caution may be appropriate here for scholars interested in recording dimensions of historical structures of the Indian subcontinent. Care is needed when relating the measured dimensions with traditional units because the metrological philosophy based on which the design

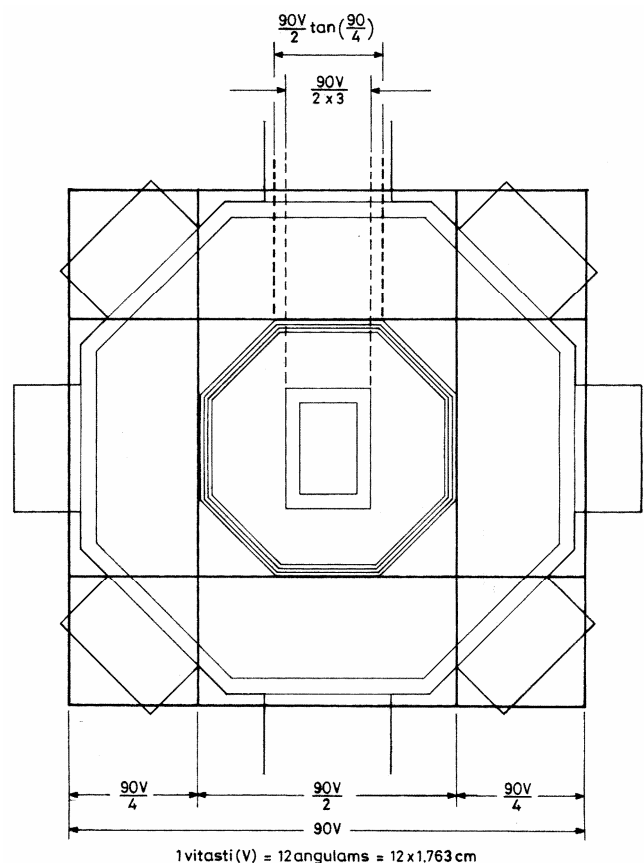

Figure 10. Proposed modular plan and predicted dimensions of the central tomb chamber of the Taj Mahal mausoleum. Notice how the central octagon has been created from the central inner square measuring $90V/2$ to the side. The *vitasti* (V) equals 12 *angulams* and each *angulam* measures 1.763 cm.

was marked out has not been understood, prior to this work. Therefore, major geometric structures on the floor patterns (as well as on elevation sections) need to be considered in actual measurements and not only the architectural elements.

Summary

The modular planning of the Taj Mahal complex at Agra has been understood in a novel approach in terms of the traditional units of measure mentioned in the *Arthashastra* using a constant *angulam* of 1.763 cm and, in particular, the *vitasti* measuring 12 *angulams*. The riverfront terrace and garden sections of the complex were planned using square grids of 90 *vitasti* to the side, while the forecourt and caravanserai section, using square grids of 60 *vitasti* to the side. The logical numbers that result for the dimensions have been analysed to show the ease of division of these numbers into symmetric elements, including decimal divisions. A novel method by which the architectural structures of the subcontinent can be understood is confirmed by the low percentage of errors between the predicted and actual measurements of the Taj Mahal complex. Traditional design principles and civil engineering skills of the Indian subcontinent were utilized in the construction of the Taj Mahal.

1. Koch, E., The construction of the Taj Mahal. In *The Complete Taj Mahal: And the Riverfront Gardens of Agra*, Thames & Hudson, London, 2006, pp. 83–101.
2. Begley, W. E. and Desai, Z. A., *Taj Mahal – The Illumined Tomb: An Anthology of Seventeenth Century Mughal and European Documentary Sources*, University of Washington Press, Washington, 1989, pp. 64–76.
3. Lahori, A. H., *Padshahnama* (eds Kabir-ud-din Ahmad, M. and Abd al-Rahim, M.), Calcutta, 1866–72, vol. 2, pp. 322–330.
4. Habib, I., Measures of land. In *The Agrarian System of Mughal India (1556–1707)*, Asia Publishing House, 1963, pp. 353–366.

5. Balasubramaniam, R., New insights on metrology during the Mughal period. *Indian J. Hist. Sci.*, 2008, **43**, 569–588.
6. Barraud, R. A., Modular planning of the Taj. In *The Complete Taj Mahal: And the Riverfront Gardens of Agra* (ed. Koch, E.), Thames & Hudson, London, 2006, pp. 108–109.
7. Barraud, R. A., Factfile. In *The Complete Taj Mahal: And the Riverfront Gardens of Agra* (ed. Koch, E.), Thames & Hudson, London, 2006, pp. 258–259.
8. Balasubramaniam, R., New insights on metrology during the Mauryan period. *Curr. Sci.*, 2008, revised version submitted.
9. Balasubramaniam, R., On the mathematical significance of the dimensions of the Delhi Iron Pillar. *Curr. Sci.*, 2008, **95**, 766–770.
10. Balasubramaniam, R., On the confirmation of the traditional unit of length measure in the estimates of circumference of the earth. *Curr. Sci.*, 2009, **96**, 547–552.
11. Shamasastri, R., *Kautilya's Arthashastra*, Translation, Mysore Printing and Publishing House, Mysore, 1939, 3rd edn.
12. Kangle, R. P., *The Kautilya Arthashastra, Part II*, Motilal Banarsidass, New Delhi, 1986, pp. 138–140.
13. Danino, M., Dholavira's geometry: a preliminary study. *Puratattva*, 2005, **35**, 76–84.
14. Danino, M., New insights into Harappan town-planning, proportions, and units, with special reference to Dholavira, *Man Environ.*, 2008, **33**, 66–79.
15. Rao, S. R., *Lothal, A Harappan Port Town*, Manager of Publications, Government of India Press, New Delhi, 1955–62, vol. II, pp. 689–690.
16. Balasubramaniam, R. and Joshi, J. P., Analysis of terracotta scale of Harappan civilization from Kalibangan. *Curr. Sci.*, 2008, **95**, 588–589.
17. Hodgson, J. A., A memoir on the length of the Illahee Guz or Imperial measure of Hindostan. *J. R. Asiatic Soc.*, **7**, 57–58.
18. Michell, G., *The Hindu Temple: An Introduction to its Meaning and Forms*, London, 1977, pp. 89–93.
19. Schinz, A., *The Magic Square: Cities in Ancient China*, Stuttgart/London, 1996, pp. 71–73.

ACKNOWLEDGEMENTS. I acknowledge the cooperation of the Archaeological Survey of India during studies on the world heritage Taj Mahal complex. I thank Michel Danino for critical comments and observations on the manuscript in particular and on matters related to metrology of the Indian subcontinent through the ages, in general.

Received 28 January 2009; revised accepted 22 May 2009